

intelligent Remote Fiber Testing System iRFTS

Overview

The intelligent Remote Fiber Test System (iRFTS) is a state-of-the-art system for administering networks of fiber optic cables. iRFTS incorporates the latest advanced embedded Micro Processor technology into Main Control Unit (MCU) for AI Smart Testing.

Centralized control and fiber network administration of the system servicing dark fiber, live fiber, PON fiber network applications.



iRFTS allows the user to perform self-reliant AI fiber monitoring and cable commissioning including: real time fiber fault detection, accurate fault analysis, reduced service down times, optical fiber degradation forecast ; and optimized monitor fiber usage for data services.

Features :

- 7x24 on-line monitoring with light source and power detector.
- Real-time optical power monitoring and fault detection.
- Fully automatic AI smart testing built into Remote Test Unit (RTU)
- Main Control Unit (MCU) is microprocessor based, providing high cyber security, stability, reliability, and minimum power consumption.
- Web base GIS interface supporting both online map or offline map down to street level.
- Providing forecast fiber report and historical report for SLA fiber subscribers.
- OTDR ghost trace filtration.
- To comply with ESG goal to reduce power consumption with MCU control card, not using IPC system.
- With the shelves cascaded mechanism to make the system capacity expansion easily growing with your need.(to saving the CPEX)
- Comparison with traditional Fiber Monitoring system as below :



Viavi/JDSU vs iRFTS

Features	Viavi/JDSU (traditional RFTS)	iRFTS (MCU)
Control module	Industrial PC	Micro Controller Unit (MCU)
Operation System (OS)	Linux based	Micro Processor (IC)
System	Server based	MCU based
Cyber Security	Low	High
Stability	Low	High
Hardware life	5-8 years	15-20 years
Fiber fault detection (with OTDR)	port scanning/polling	Port scanning/polling
7x24hrs real time (*1) detection and monitoring	no	Yes
Fiber Fault Analysis	Server based commands	AI RTU
Smart Testing (*2)	no	yes
Multi fiber faults	no	yes
Ghost trace filtration	no	yes
Software customization	no	yes

*1 : to provide the real time fault detection and monitoring with on-line light source(always on) and power detection module.

*2 : Smart testing ability to auto readjust OTDR parameters for high accuracy. For example: Given 90km fiber length fault at 5km, AI RTU will auto run 120km, 60km, 30km, 15km, 7.5km OTDR parameters for highest accuracy result.

Ability to process multiple fiber fault at the same time

System Diagram

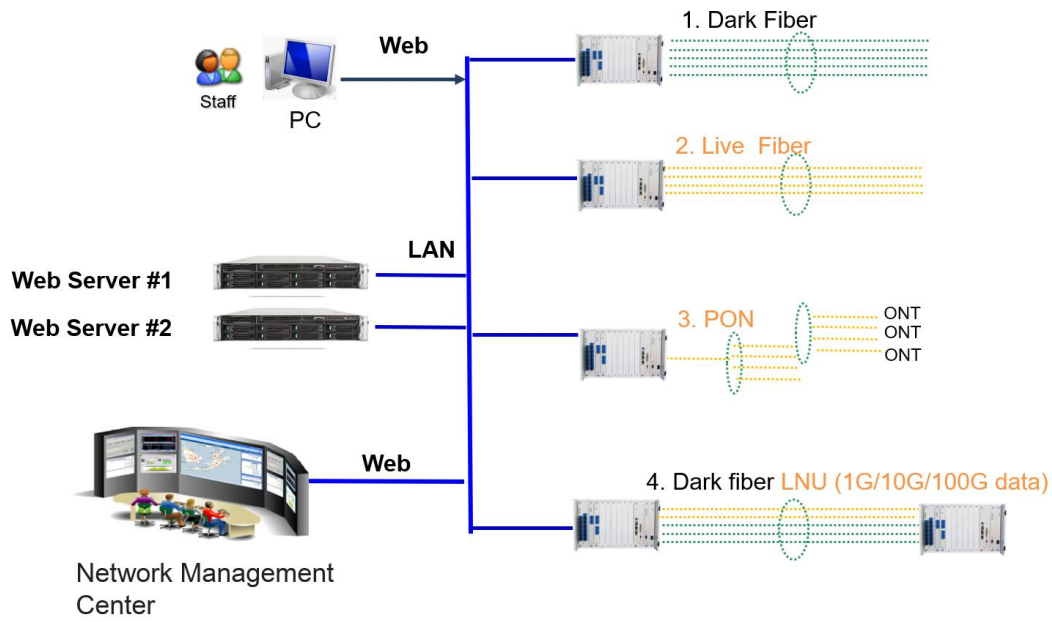

Application Scenarios :

Scenario 1 : Point to Point

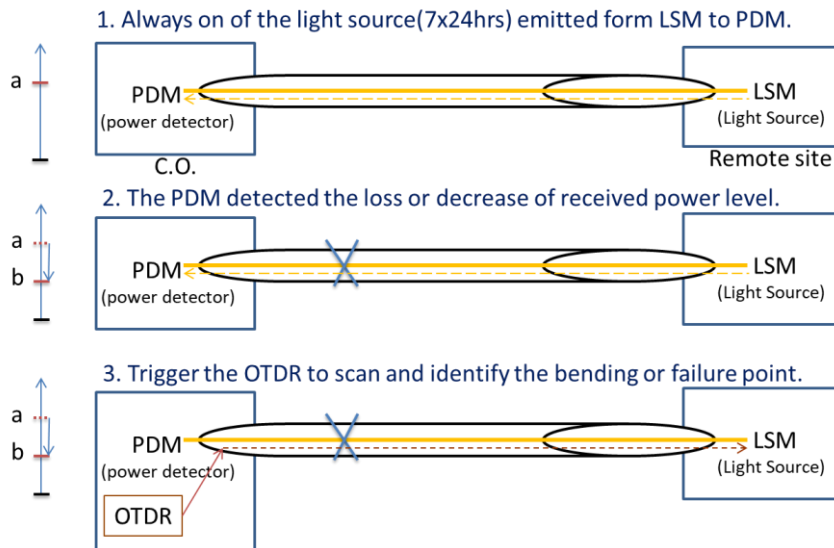

Scenario 2 : a circle loop

1. To choose one fiber core per path and connected as a circle loop (A>B>C>D>A)
2. Always on of the light source(7x24hrs) emitted from LSM to PDM.
3. The PDM detected the loss or decrease of received power level.
4. Trigger the OTDR to scan and identify the bending or failure point.

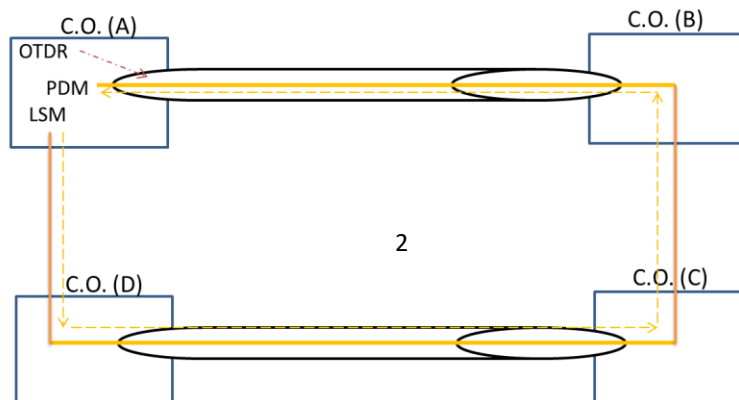

Friendly Web Server Interface

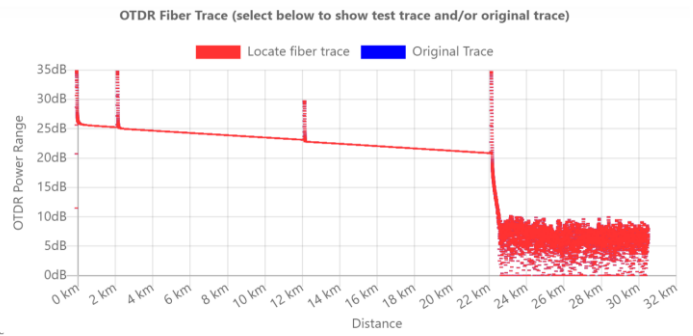
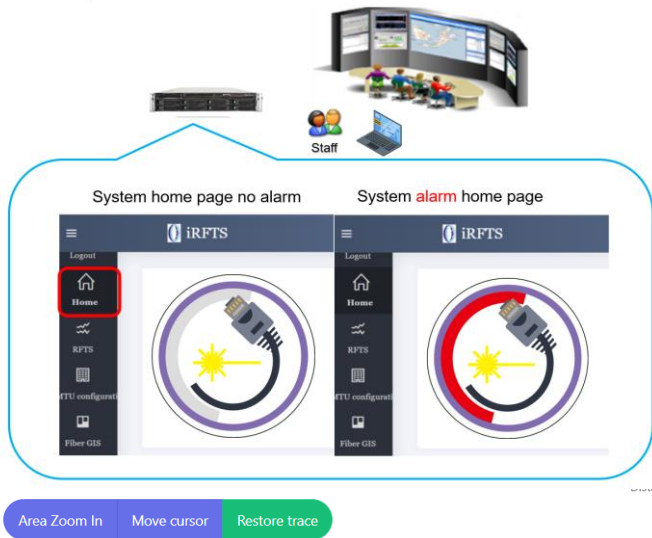

OTDR Event log

Event type	Mode	Connection loss	Location	Power Level	Reflection	Total Loss	Event Loss
=== Testing fiber Events ===							
Start	Auto	0 dB	0.03366 km	31.53 dB	0 dB	0 dB	0.000 dB/km
Connector	Auto	0.185 dB	2.18484 km	25.25 dB	40.384 dB	-6.28 dB	2.919 dB/km
Connector	Auto	0.285 dB	12.18798 km	23.25 dB	46.414 dB	-8.28 dB	0.200 dB/km
End	Auto	0 dB	22.18194 km	20.84 dB	31.608 dB	-10.69 dB	0.241 dB/km
=== Original fiber Events ===							
Start	Auto	0 dB	0.03366 km	31.53 dB	0 dB	0 dB	0.000 dB/km
Connector	Auto	0.185 dB	2.18484 km	25.25 dB	40.384 dB	-6.28 dB	2.919 dB/km

GIS Interface



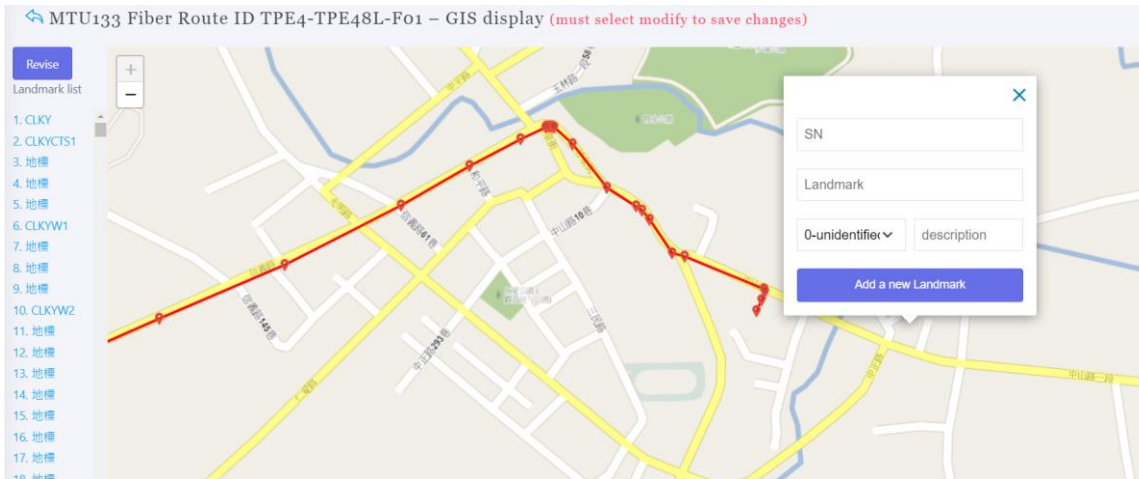









Reference Customers :

- Chung-Hwa Telecom (CHT, the largest telecom operator in Taiwan)
- Fareastone Telecom (FET, 2nd largest telecom operator in Taiwan)
- iForte (Telecom operator in Indonesia)
- Taiwan Railway Company (Taiwan)
- Taiwan High Speed Rail Company
- China Oil Company (Taiwan)
- Military Affiliate (Taiwan)

Potential Customers :

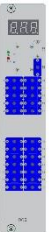
- Telco Operators : Core/Metro Fiber Network, Data Center Links.
- Cloud Operators : 100Gbps, 400Gbps or above Fiber links to connect two sites.
- ISP operators : to connect the different data centers with ultra bandwidth needs.
- Cable Operators : Core or Metro Fiber Network.
- Government or Utility : with high bandwidth needs or important fiber links.
- Education Network.
- DWDM Leased line and links for banks.
- Military important fiber links.
- Submarine Providers (<= 320Km length.)

Hardware Specifications

Chassis			
Open slots	12 slots		
Cascade Chassis	via RS485		
Rack mountable	19" or 23" , Height less than 7U		
Dimension	484(W) x 308 (H) x 329(D) mm		
Power Supply module			
	DC power	DC -36 ~ -72V	
	AC power	AC 110V~220V, 60±5% HZ	
	Maximum output	150 watt	
	Fuse	3A	
MCU Module			
	Processor	80188 or higher	
	Memory	512 k or higher	
	Storage	24 Mbytes or higher	
	Interfaces	10/100 Ethernet and Console (RS-232)	
	System maintenance	Supports Watch Dog self diagnostic	
	LED display	Hardware LED: RUN, Fail, OTDR, OCS, LSU, PMU	
	Fiber LED: Alarm		
	System protocols	North bound system integration commands and protocols can be provided upon request	
OTDR module			
	Operation wavelength	1550nm or 1625nm ±20nm	
	Dynamic range	≥ 32dB, 35dB, 38dB, 43dB, 45dB	
	X-axis resolution	≤ 25cm	
	Y-axis resolution	≤ 0.001dB	
	Refraction index	1.200~1.600 each step, 0.0001	
	Accuracy	±1.0m ± (3√10 ⁻⁵ distance) ± sampling resolution	
	Pulse width	At least 5 different pulse widths: 3ns, 5ns, 10ns ~100, 200ns ~ 500ns, 1us ~ 5us, 10us ~ 20us	
	Max. Sampling points	256,000	
OCS module			
	Switching time	≤ 300ms	
	Passband	±20nm @1550nm / 1625nm	
	Return loss	≥ 45dB	
	Insertion loss	≤ 1.5dB	
	Crosstalk	≤ -70dB	
	Repeatability	≤ 0.1dB	
	Life time	10 million switching times	
	Optical Interface	SC/PC, SC/APC, or LC/PC	
LSU module			
	Operation wavelength	1550nm	
	Laser source	2 laser sources	
	Center wavelength	± 25nm	
	Linewidth	≤ 5nm	
	Output power	≤ -7 dBm @ 4 ports	
	Stability @25°C 24hour	≤ 0.3dB	
	Optical Interface	SC/PC, SC/APC, or LC/PC	
PMU module			
	Operation wavelength	1280nm ~ 1655nm	
	Dynamic range	5 dBm ~ -65 dBm (Dark fiber) +15 dBm ~ -40 dBm (Live fiber)	
	Accuracy	≤ 0.5dB	
	Resolution	≤ 0.1dB	
	Optical Interface	SC/PC, SC/APC, or LC/PC	
WDM module			
	Operation wavelength	1310nm & 1550nm / 1625nm	
	Directivity	≤ -50dB	
	Insertion loss	≤ 1.5dB	
	Isolation	≤ -30dB	
	Optical Interface	SC/PC, SC/APC, or LC/PC	

Specification may subject to latest update without notice